

Double Chuck Lath Machine for Glass Manufacturing:

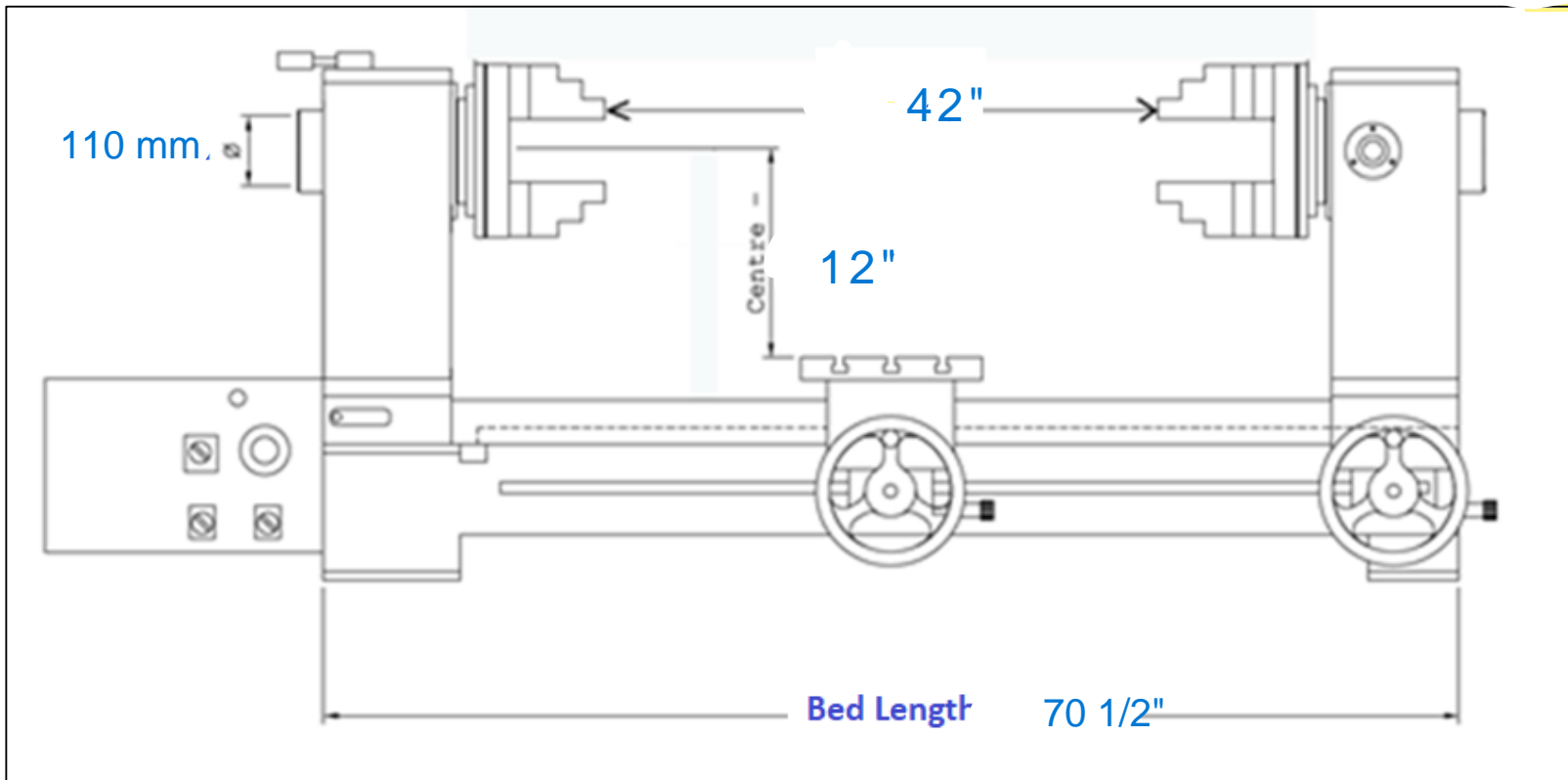

Frequency = 50 Hz

chucks move on a single rod --- Chuck teeth closes on zero

Input Voltage 220 Volt & 110 Volt

Check Concentricity = $\leq 0.05\text{mm}$

Speed Controller 0 to 1540 RPM